

Iceland Deep Drilling Project (IDDP) – Fluid Handling and Evaluation

Kristinn Ingason, Albert Albertsson, Bjarni Pálsson, Claus Ballzus, Halldór Ármannsson, Jónas Matthíasson, Sverrir Þórhallsson, Teitur Gunnarsson

Mannvit, co Kristinn Ingason, Grensásvegur 1, 108 Reykjavík, Iceland

kristinn@mannvit.is

Keywords: Iceland Deep Drilling, supercritical steam, superheated steam, geothermal utilization

ABSTRACT

The first IDDP well was drilled in the Krafla geothermal area in the first half of 2009. The plan was to drill into a high-temperature hydrothermal system with the aim of finding superheated or supercritical fluid at a temperature of 400 – 600 °C at a depth below 3.5 km. However, the drilling was stopped at a depth of 2100m , as it became clear that the drill rig had drilled into magma. The thermodynamic and chemical properties of the fluid expected to flow from the well are unknown. The IDDP fluid handling and evaluation group (FHE) has been developing a plan for the characterization of the fluid and its subsequent utilization for energy production. This plan is outlined in the paper. The design and material selection are discussed, and the logging and measuring programs are described.

1. INTRODUCTION

The drilling of IDDP-1 in the Krafla geothermal area started in late 2008 when the first 800 m were drilled and cased. The drilling continued in the spring of 2009 and the plan was to drill to 4.5 km depth. The drilling was, however, stopped at 2100 m depth in July, 2009, when it became clear that the drill rig had drilled into magma. The final depth of the well is 2072 m and it is cased down to 1949 m. Figure 1. shows the construction of the well.

A flow test is planned to start in the autumn of 2009. Although the fluid from the well will not be supercritical, as the pressure will not be high enough, it may be superheated and of unknown thermodynamic and chemical properties.

When contemplating the initial production of a geothermal fluid of unknown chemical composition from a well drilled into an unfamiliar environment, one is presented with a dilemma. On the one hand, fluid must be extracted from the well for some period of time, even if only on a pilot scale, in order that its properties may be studied and an appropriate energy extraction process found. This very production may, on the other hand, result in permanent damage to the well, either because of corrosion of the casing, or because of solid deposition in the aquifer or the wellbore.

To address this dilemma a scheme that came to be known as “the Pipe” was proposed. By inserting a liner into the well through which the fluid would flow, the well casing would be protected. The “Pipe” would give important information on corrosion and scale formation at different pressures and temperatures. This plan was, however,

abandoned ,at a later stage of preparation, because of cost and the danger of the “Pipe” itself breaking and preventing the well from discharging.

The well will therefore be tested in a conventional way, but the test will be divided into phases. Experience gained in the earlier part of the test will be used to modify the design conditions for the later phases. The equipment used will be of conventional design, but adapted to the extreme conditions which may obtain at the wellhead.

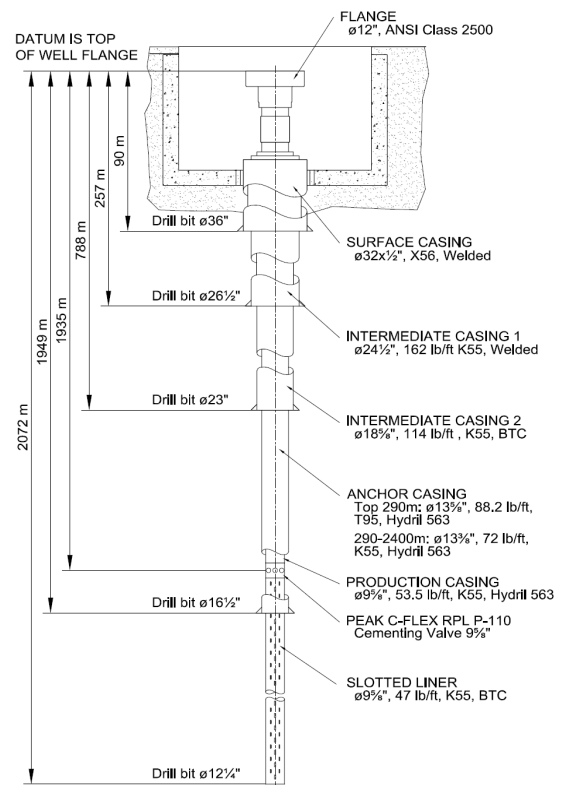

Figure 1: Wellhead during heating-up period

2. FLOW TESTING

Once the drill rig has been removed from the well, a wellhead as shown in Figure 2, will be installed. This will be the wellhead present during the heating-up period. It will be possible to pump water into the well, to vent gas from the well, to measure temperature and pressure, and to run measuring tools down the hole.

The flow test is divided into three phases, which are described in the following text.

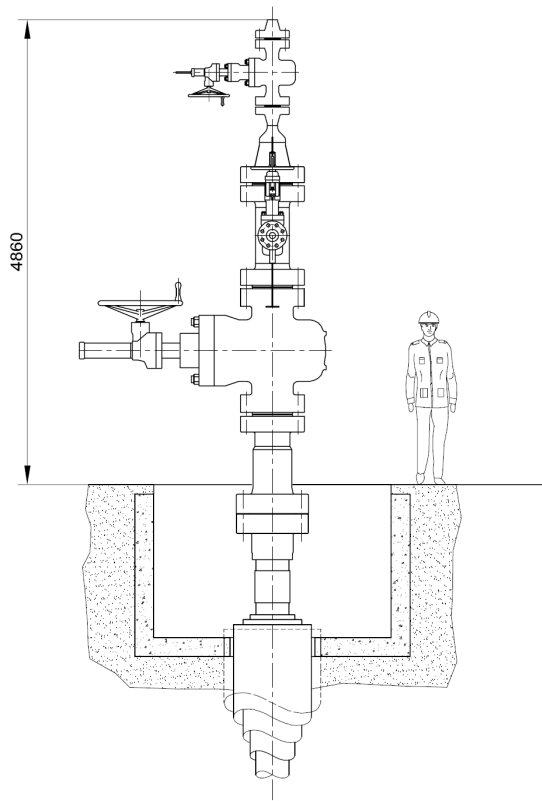

Figure 2: Wellhead during heating-up period

2.1 Phase 1, Initial Flow

When the well is ready to discharge, the wellhead will be modified, i.e. replaced with the wellhead shown in Figure 3. This wellhead is designed in order that measuring tools may be run down the hole. Thus pressure and temperature can be measured, and, if necessary, the well can be killed by pumping water through two $\varnothing 3''$ valves.

Due to a high water level, it may be difficult to make the well discharge. In such a case airlift will be applied to the well.

The goal of the initial flow test is to obtain samples of the well fluid. Such samples may be collected by a downhole sampler, but the well will probably have to be discharged if a sample uncontaminated by drilling fluids is to be obtained. Initially, the well will discharge through a $\varnothing 4''$ pipe. The pipe and fittings will be thick-walled and made of carbon steel. The well may have to discharge for some time, up to four weeks, before a sample, representing the geothermal fluid in the well, can be collected. The sample will be used to characterize the chemical composition of the fluid. The pressure and temperature at the well head will be measured at this time. A diagram of the layout in Phase 1 is shown in Figure 4.

$\varnothing 1''$ nozzles will be used for collecting samples of the fluid. The flow of the fluid will be determined by measuring the pressure drop across an orifice plate. The flow from the well and the wellhead pressure will be controlled by a selection of orifices.

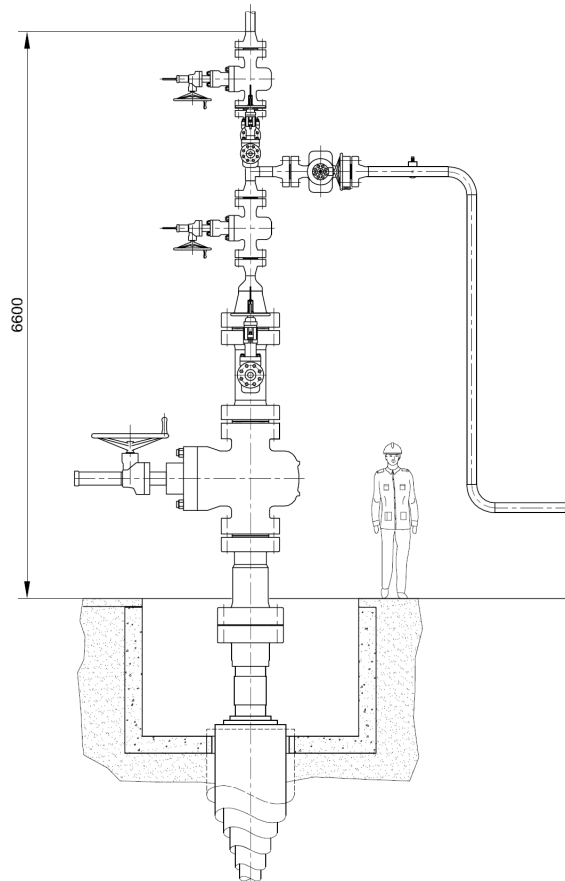

Figure 3: Wellhead during initial flow of the well, phase 1

2.2 Phase 2, Full Flow

The information gathered in Phase 1 will be used to design and construct equipment to perform a full flow test of the well, which will be carried out in Phase 2. The yield of the well will be tested and additional fluid samples will be collected. This will add to the information gathered in phase 1 and will be used for the design condition in Phase 3. The diagram in Figure 5 shows the layout in Phase 2.

2.3 Phase 3, Pilot Plant

The third and final phase of the flow test concerns the question of how the well fluid can be utilized. The method chosen will depend on the data gathered in Phases 1 and 2. Information on the chemical properties of the fluid is especially important for material selection and process design. Particular consideration will be given to adapting the energy extraction process to the fluid properties so as to maximize its efficiency.

3. DESIGN

3.1 Design Conditions

The design conditions for the equipment at the wellhead depend on the conditions downhole and the flow up the well.

The IDDP design premises were initially chosen on the basis of estimates of bottom-hole temperatures and pressures at a depth of 5,000 m. The temperature and pressure in the well were assumed to follow the boiling point curve for fresh water to a depth of about 3,500 m where the critical temperature (374.15 C) and pressure

(22.12 MPa) would be reached. Below this depth, two possibilities were considered, viz.:

- A linear temperature gradient yielding a temperature of about 550°C and a pressure of 25 MPa at 5000 m depth.
- An isochoric path yielding 391°C and 26.7 MPa at a depth of 5,000 m.

The above premises are being used to determine the relevant loading conditions for the upper portion of the well and for the wellhead, both for a flowing well and for a closed well.

a) Flowing well

The calculated flow through the production casing is estimated to bring the pressure and temperature at the wellhead flange to about 18 MPa and 470 C, respectively, given a bottom hole temperature and pressure of 550 C and 25MPa, respectively. The isochoric path case yields a lower wellhead temperature and pressure.

b) Closed well

If the well is assumed to be filled with saturated steam above 3,500 m, the presumed depth to the

critical point, the following temperature and pressure conditions are obtained:

	Conditions at wellhead	
	T [°C]	P [MPa]
Linear extrapolation	364	19.7
Isochoric path	369	20.9

In addition to the above it is considered prudent to make estimates of two additional wellhead load conditions, namely: i) at 20°C and a higher bottom hole pressure, i.e. 26.7 MPa, and ii) at 400°C and 22 MPa.

Three alternative temperature and pressure parameters were selected for assessing load and stress conditions in the upper part of the anchor casing and the wellhead.

Discharging well:

- T= 470°C og P= 18 MPa

Closed well:

- T= 400°C og P= 22 MPa
- T= 20°C og P= 26.7 MPa

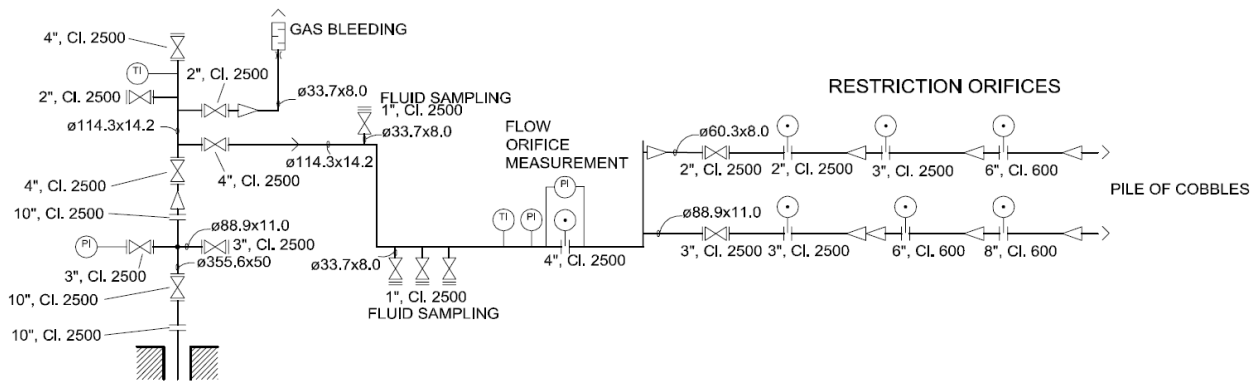

Figure 4: Diagram showing piping and equipment planned for the initial flow of the well, phase 1

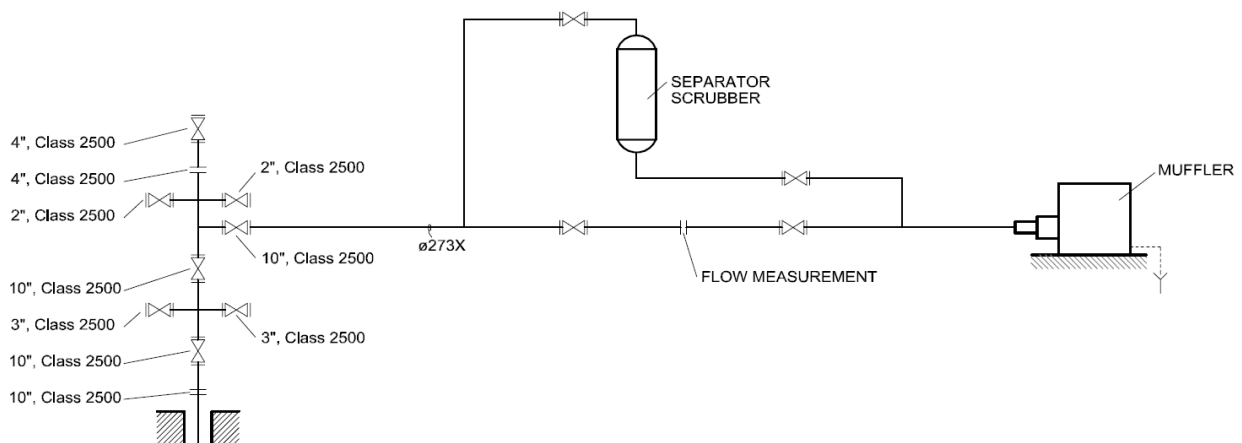

Figure 5: Diagram showing piping and equipment planned for the full flow test of the well, phase 2

These conditions are shown in Figure 6 along with the temperature – pressure rating of Class 2500 flanges, material group 1.9, and a Class 1500 valve with Class 2500 flanges, also material group 1.9.

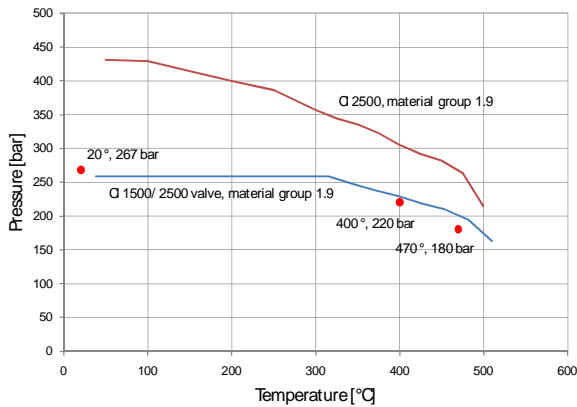

Figure 6: Temperature-pressure rating of Class 2500 flanges and a Class 1500 valve with Class 2500 flanges

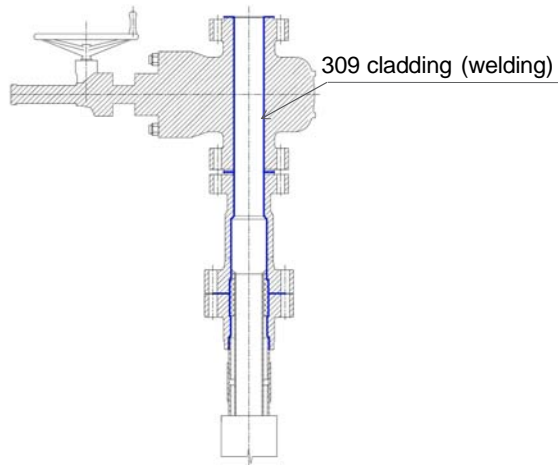

Figure 7: Cladding of valve and expansion spool at the wellhead

3.2 Material Selection

Since no information is available about the composition of the fluid from the IDDP well, the FHE group originally proposed the use of a separate liner inside the well that could be replaced in case of severe corrosion or scaling. This solution was rejected due to high cost and risk.

By comparing possible scenarios to known high-temperature well fluids, it was concluded that the most detrimental effects of the fluid would be either scaling or hydrogen chloride corrosion. Judging from experience from Larderello and the Geysers, the hydrogen chloride content could be as high as 100-1,000 ppm. Steam washing with dilute NaOH has been applied for many years to protect steam gathering and power generating equipment (Hirtz et al. 1990). Recently, a dry-steam scrubbing technology has been developed for removal of corrosive hydrogen chloride from superheated steam without superheat quenching (Hirtz et al. 2002).

Another possible effect of the fluids is corrosion or embrittlement caused by hydrogen or hydrogen sulfide gases. Hydrogen sulfide can react with iron and release hydrogen atoms that can diffuse into the steel. This process

is enhanced by moisture. In existing wells in the Krafla field, the steam contains considerable hydrogen sulfide and some hydrogen as well.

Due to the uncertain fluid composition, the FHE group proposed the use of conventional steel such as 16Mo3 for the initial wellhead and flow testing equipment. The group focused on meeting the pressure and temperature criteria and on granting ample corrosion allowance. Maintaining at least 20 C superheat will prevent the steam from condensing and the HCl from forming hydrochloric acid. To avoid HCl condensation, the wellhead needs to be thoroughly insulated with a material that is stable at the anticipated temperature, such as aluminum-silicate wools (ASW) or refractory ceramic fibers (RCF). This type of insulation can be used at temperatures up to at least 900 C.

The 16Mo3 steel that was selected has an ultimate tensile strength of 650 MPa and a hardness of 23 HRC and is not considered susceptible to hydrogen embrittlement.

4. LOGGING AND MEASURING PROGRAM

4.1 Logging Program

4.1.1 Logging 0-2400 m

The original plan called for a conventional logging program down to 2400 m. This means that at each casing depth the temperature, pressure, width, and geological strata are logged. When cementing is completed, temperature and pressure logging is repeated and the quality of the cementing logged.

4.1.2 Logging 2400-3500 m

Logging is carried out through a lubricator, made from 5" drill pipe, extending down past the BOP's. The annular BOP will be closed around the pipe while logging. The pipe has a seal for the wireline at the top. The pressure rating is API 5M. A minimum flow of 30L/s will be maintained on the kill line at all times.

4.1.3 Logging 3500-4500 m

Logging is carried out through a pipe (lubricator) extending from the rig floor to a position below the BOP's. The annular BOP will be closed around the pipe while logging. The pipe has a seal for the wireline at the top. The pressure rating is API 5M. A minimum flow of 30 L/s will be maintained on the kill line at all times.

Table 1. Logging in the 12¼" Hole. Expected Duration in Hours and Number of Logging Runs.

Type	Time [h]	No. of logs
Temperature	4.1	5
Pressure	4.1	1
Caliper	3.7	1
Televiwer	11.4	1

Table 2. Logging in the 8½" Hole.

Type	Time [h]	Nr. logs
Temp	5.0	6
Press	5.0	5
Wireline	5.9	2

4.2 Measurement Program

4.2.1 Enthalpy and Flow Measurements

Enthalpy and flow measurements will be carried out at regular intervals as soon as the well starts discharging. They will be based on temperature and pressure measurements at orifice plates.

4.2.2 Chemical sampling and chemical monitoring

Preparations are being made to receive fluid that may reach a temperature of 470 °C and a pressure of 18 MPa at the wellhead. The horizontal pipeline leading from the wellhead will be fitted with a sampling point and valves that can be operated at these conditions. The point will be located about 1.5 m from the wellhead.

One valve at the point will be fitted with an efficient heat exchanger or cooling coil that permits rapid quenching of the fluid to ambient temperature. A simple room-temperature gas-liquid separator will be provided, and connected to the heat exchanger on the downstream side, so that the gas and the condensate can be sampled separately, and their flow rates measured simultaneously. This arrangement will be used if the well fluid is superheated or supercritical steam, as hoped.

A corrosion-resistant steam-liquid separator that can be operated under the conditions of temperature and pressure mentioned above has been designed. It will be installed at the sampling point. Both the steam and the liquid outlets of

the separator will be fitted with an efficient heat exchanger or cooling coil. This separator will be used only if the well discharges a steam-water mixture.

Samples of the well fluids will be collected at various times during the well test, most frequently at the outset. These samples will be analyzed for all major elements and a significant number of trace elements. The chemical components analyzed include those required for a coherent picture of the fluid geochemistry, as well as all those deemed necessary for material selection for the following stage of the project, the pilot plant.

REFERENCES

- Albertsson, A., Bjarnason J.Ö., Gunnarsson, T., Ballzus, C., Ingason, K.: IDDP Feasibility Report, Part III, Fluid Handling and Evaluation, May 2003.
- Hirtz, P., Miller, J., and Prabhu, E.: Operational Results of a Dry-Steam Resource Chloride Corrosion Mitigation System. Geothermal Resources Annual Meeting, Transactions 1990.
- Hirtz, P., Broaddus, M.L., and Gallup, D.L.: Dry Steam Scrubbing for Impurity Removal from Superheated Geothermal Steam. Geothermal Resources Council Transactions 2002.
- Thorhallsson, S., Matthiasson, M., Gislason, Ingason, K., Palsson, B., Fridleifsson G. O.: IDDP Feasibility Report, Part II, Drilling Technology, May 2003.